

"Schutzvermerk nach DIN ISO 16016 beachten." "Please pay attention to copyright note DIN ISO 16016."

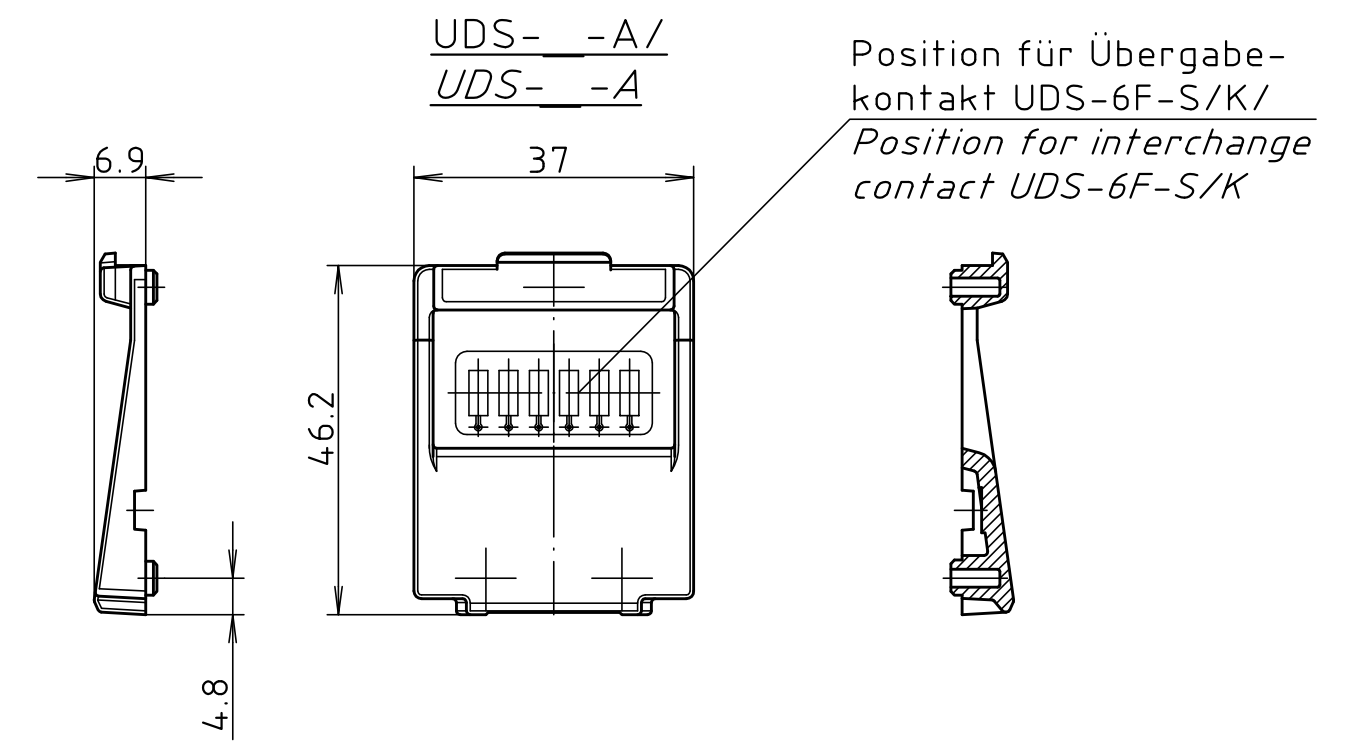

UDS - Rastvorgang/
UDS - locking process

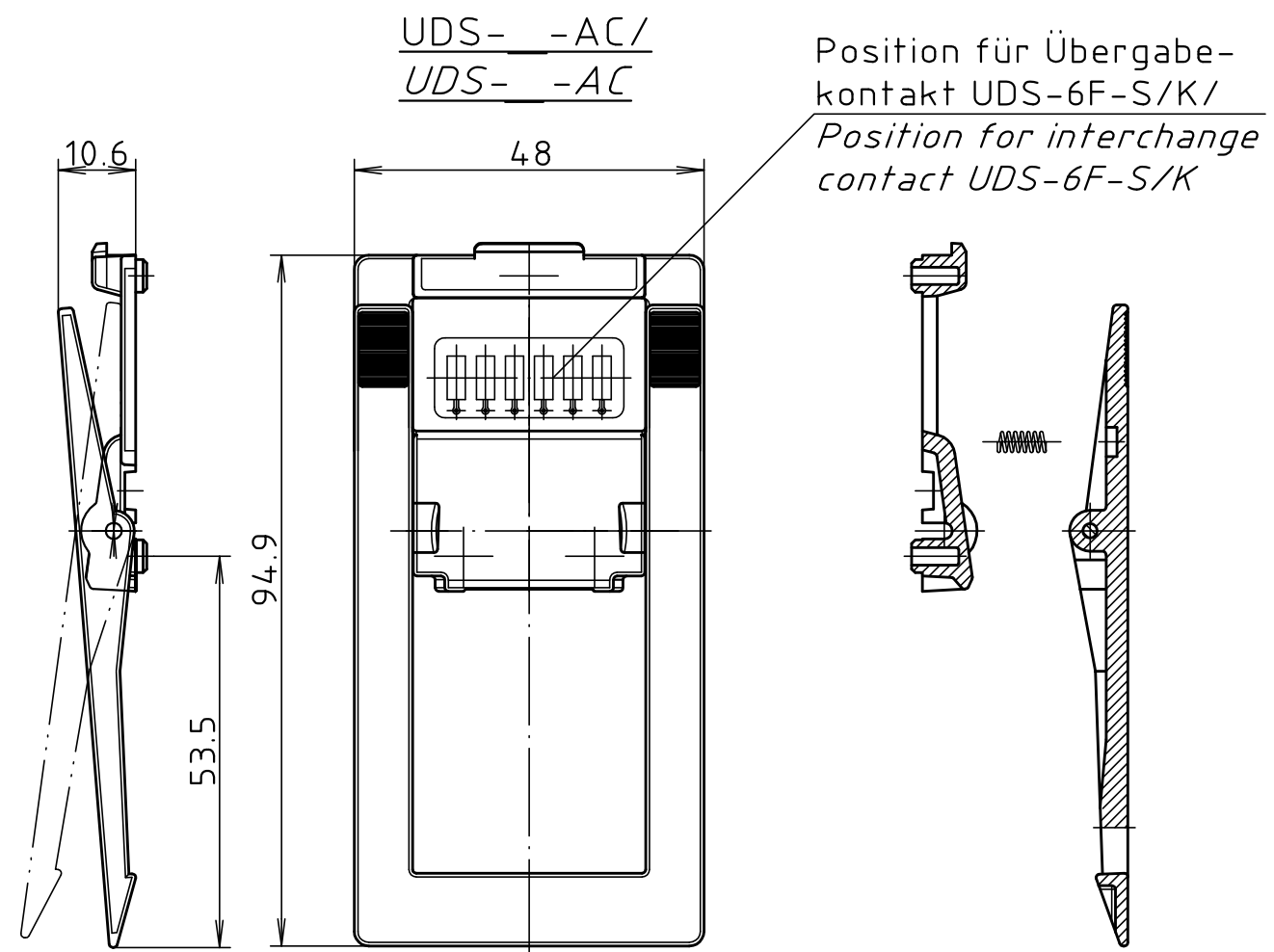
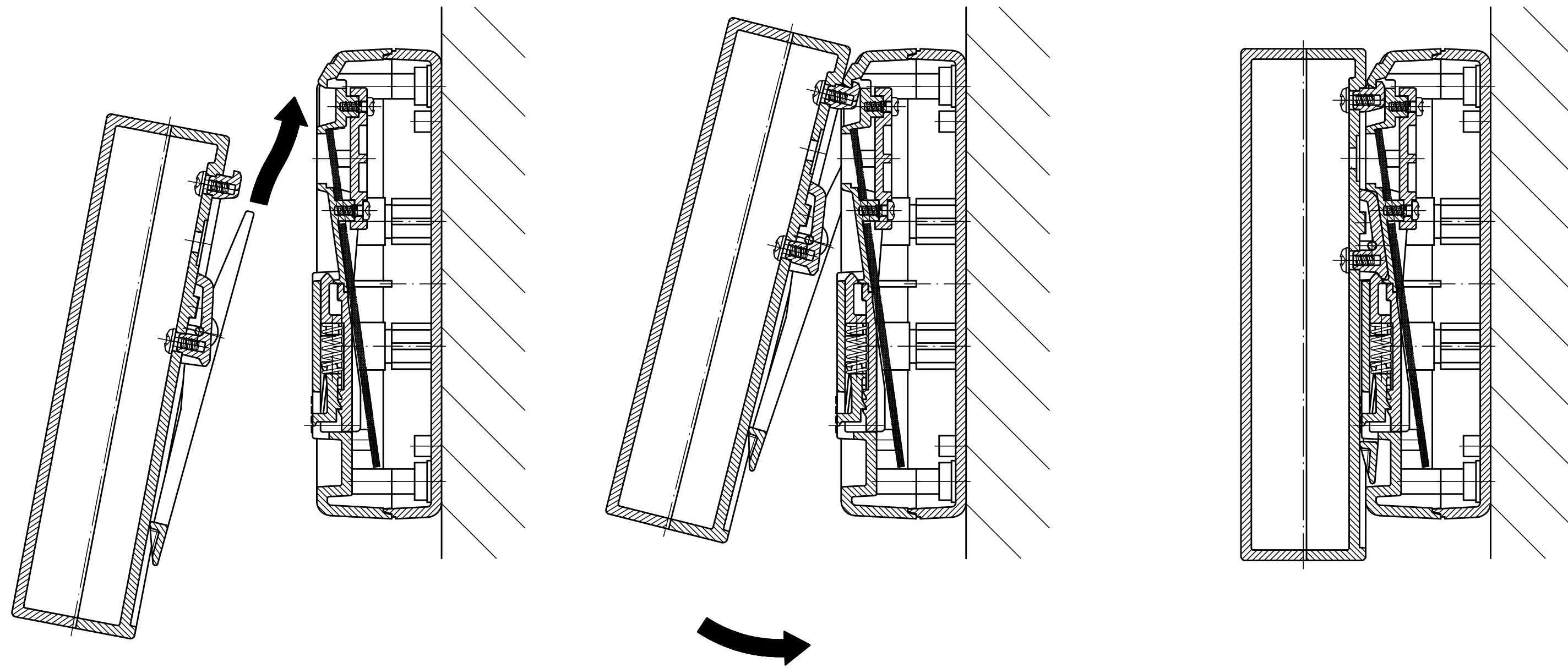

Maßstab/
Scale: 1:1

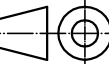

Zeichnungs-Nr. / Drawing-No.:
2K 5290.042.01

Artikel / Article:
UDS-A/AC
Katalogzeichnung/
Catalogue drawing

A Nr. / Datum/
Alt-No. / Date:
DISK: 2 801 949
Datum / Date: 14.09.99 KH

BOPLA
A Phoenix Mecano Company